

User Manual

DT-150P-M1

Medical-Grade Monitor



About This Document

No part of this publication may be reproduced, transmitted, transcribed, stored in a retrieval system, or translated into any language or computer language, in any form or by any means, including, but not limited to, electronic, magnetic, optical, chemical, manual, or otherwise without prior written permission of MicroTouch™ a TES Company.

The information in this document is subject to change without notice. MicroTouch™ a TES Company makes no representations or warranties with respect to the contents herein, and specifically disclaims any implied warranties of merchantability or fitness for a particular purpose. MicroTouch™ a TES Company reserves the right to revise this publication and to make changes from time to time in the content hereof without obligation of MicroTouch™ a TES Company to notify any person of such revisions or changes. Windows is a registered trademark of Microsoft, Inc. Other brand or product names are trademarks of their respective holders.

Compliance Information

For FCC (USA)

This equipment has been tested and found to comply with the limits for a Class B digital device, pursuant to part 15 of the FCC Rules. These limits are designed to provide reasonable protection against harmful interference in a residential installation. This equipment generates, uses, and can radiate radio frequency energy, and if not installed and used in accordance with the instructions, may cause harmful interference to radio communications. However, there is no guarantee that interference will not occur in a particular installation. If this equipment does cause harmful interference to radio or television reception, which can be determined by turning the equipment off and on, the user is encouraged to try to correct the interference by one or more of the following measures:

- Reorient or relocate the receiving antenna.
- Increase the separation between the equipment and receiver.
- Connect the equipment into an outlet on a circuit different from that to which the receiver is connected.
- Consult the dealer or an experienced radio/TV technician for help.

This device complies with part 15 of the FCC Rules. Operation is subject to the following two conditions: (1) this device may not cause harmful interference, and (2) this device must accept any interference received, including interference that may cause undesired operation.

For IC (Canada)

CAN ICES-3(B)/NMB-3(B)

For CE (EU)

The device complies with the EMC Directive 2014/30/EU and Low Voltage Directive 2014/35/EU

Renseignements relatifs à la conformité

Pour la FCC (États-Unis).

Ce matériel a fait l'objet d'essais qui ont déterminé qu'il respectait les limites d'un appareil de classe B selon la partie 15 des règlements de la FCC. Ces limites sont établies pour assurer une protection raisonnable contre les parasites nuisant à une installation résidentielle. Ce matériel génère, utilise et peut émettre des ondes radio électriques, et lorsqu'il n'est pas installé et utilisé selon les instructions, peut causer des parasites nuisant aux communications radio. Il n'y a toutefois aucune garantie qu'il n'y aura pas de parasites dans une installation en particulier. Si ce matériel cause des parasites à la réception d'ondes radio ou de télévision, ce qui peut être déterminé en l'éteignant et en l'allumant, l'utilisateur est invité à essayer de corriger le problème des parasites par l'une ou l'autre des mesures suivantes :

- Réorienter ou déplacer l'antenne de réception.
- Augmenter la distance entre le matériel et la réception.
- Brancher le matériel dans une prise sur un autre circuit que celui où le récepteur est branché.
- Consulter le distributeur ou un technicien radio ou TV expérimenté pour des conseils.

L'appareil respecte la partie 15 des règlements de la FCC. Le fonctionnement doit respecter les deux conditions suivantes : 1) cet appareil ne doit pas causer de parasites et (2) cet appareil doit accepter tous les parasites reçus, notamment ceux pouvant causer un fonctionnement non voulu.

Pour Industrie Canada

Norme canadienne NMB-3(B)

Pour la CE (UE)

L'appareil respecte la directive 2014/30/UE relative à la compatibilité électromagnétique et la directive 2014/35/EU sur les limites de basse tension

Usage Notice



Warning - To prevent the risk of fire or shock hazards, and do not expose the product to moisture.



Warning - Please do not open or disassemble the product as this may cause electric shock.



Warning - Power cord shall be connected to a socket-outlet with earthing connection.



Warning - The cable cover cannot be removed under normal use conditions.



Warning - **Stability Hazard.** The touch monitor may fall, causing serious personal injury or death. To prevent injury, this touch monitor must be securely attached to the wall in accordance with the installation instructions.

Precautions

Please follow all warnings, precautions and maintenance as recommended in this user's manual to maximize the life of your unit.

Do :

- Turn off the product before cleaning.
- Use a soft cloth moistened with mild detergent to clean the product housing.
- Use only the qualified power adapter that comes with your device.
- Disconnect the power plug from AC outlet if the product is not going to be used for an extended period of time.

Don't :

- Do not use abrasive cleaners, waxes or solvents for your cleaning.
- Do not operate the product under the following conditions:
 - Extremely hot, cold or humid environment.
 - Areas susceptible to excessive dust and dirt.
 - Near any appliance generating a strong magnetic field.

Avis d'utilisation



Mise en garde — Pour prévenir les risques d'incendie ou d'électrocution, ne pas exposer le produit à l'humidité.



Mise en garde — Prière de ne pas ouvrir ou démonter le produit, car cela pourrait entraîner l'électrocution.



Mise en garde – Le cordon d'alimentation doit être branché à une prise pourvue d'une mise à la terre.



Mise en garde – La gaine du câble ne doit pas être retirée en conditions normales d'utilisation.



Mise en garde — Risque de renversement. Le moniteur tactile peut se renverser et causer de graves blessures corporelles, voire la mort. Pour prévenir les blessures, ce moniteur tactile doit être solidement fixé au mur selon les instructions d'installation.

Précautions

Veillez suivre toutes les mises en garde, précautions et entretiens recommandés dans ce manuel d'utilisation pour maximiser la durée de vie de votre unité.

À faire :

- Éteindre l'appareil avant de le nettoyer.
- Utiliser un chiffon humidifié par une solution savonneuse pour nettoyer le boîtier du produit.
- Utiliser uniquement l'adaptateur d'alimentation prescrit pour votre appareil.
- Débrancher l'appareil lorsqu'il n'est pas utilisé pendant une période prolongée.

À éviter :

- Ne pas utiliser de nettoyeurs abrasifs, de cires ou de solvants pour le nettoyage
- Ne jamais utiliser l'appareil dans les conditions suivantes :
 - des conditions environnementales extrêmes (chaud, froid ou humidité)
 - des endroits remplis de poussières et de saletés.
 - à proximité d'appareils produisant un fort champ magnétique.

Table of Contents

| | |
|--------------------------------------|-----------|
| Chapter 1 | 7 |
| 1.1 Overview | 8 |
| 1.2 Feature | 8 |
| 1.3 Specifications | 8 |
| 1.4 Block Diagram | 9 |
| 1.5 Interface Connectors | 10 |
| 1.5.1 Power Connector | 10 |
| 1.5.2 Video Signal Connector | 10 |
| 1.5.3 Signal Connector | 12 |
| 1.6 Package Overview | 13 |
| Chapter 2 | 14 |
| 2.1 About VESA Mount | 15 |
| 2.2 On-Screen Display | 16 |
| 2.2.1 OSD Function Description | 18 |
| 2.2.2 Timing Table Chart | 19 |
| 2.2.3 EDID Data | 19 |
| 2.3 Dimension | 20 |
| 2.3.1 Front View | 20 |
| 2.3.2 Side View | 20 |
| 2.3.3 Rear View | 21 |
| Appendix | 22 |

Chapter 1

Product Introduction

1.1 Overview

The DT-150P-M1 series is a 15" touchscreen monitor that builds to withstand commercial grade open frame monitor, with stylish thin cable management bracket and versatile design DT-150P-M1 is an exceptional choice for applications for all business sectors and well suited for point-of-sales, point-of-information, point-of-service and interactive signage.

1.2 Feature

- Cable management bracket design for easy organize cable.

1.3 Specifications

| LCD Touch Panel | |
|-----------------------|---|
| Size | 15" TFT LCD |
| Brightness | 350 cd/m ² (Non-touch screen) 297 cd/m ² (P-cap touch with AG Coating) |
| Number of Pixels | 1024 (H) × 768 (V) |
| Touch Type | P-CAP/ 10 points |
| Environment | |
| Certificate | CE, CB, FCC, UL, CCC, RoHS, IEC60601-1-2 4th edition compliant |
| Compliance | Front Panel IP54 |
| Operating Temperature | 0°C ~ 40°C |
| Storage Temperature | -20°C ~ 60°C |
| Operating Humidity | 20% ~ 80% RH, non-condensing |
| Mounting | VESA 100 mm x 100 mm |
| Dimension (W x H x D) | 337.4 mm x 304.2 mm x 200.9 mm |
| Net Weight | 4.4 kg |
| Gross Weight | 6 kg |

1.4 Block Diagram

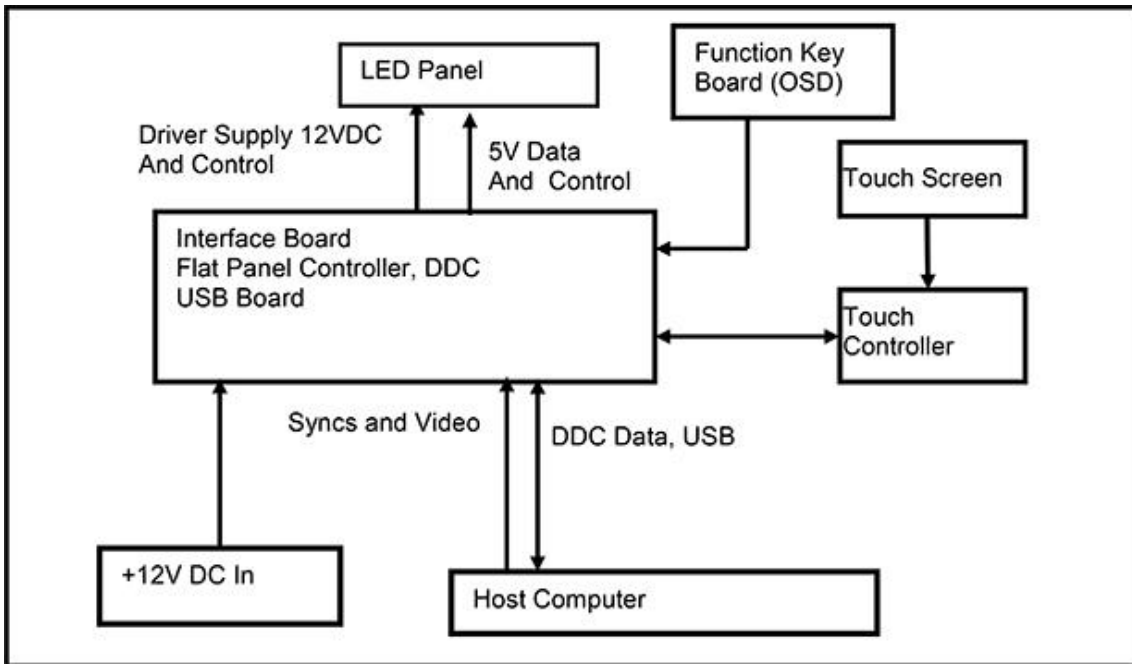

1.5 Interface Connectors

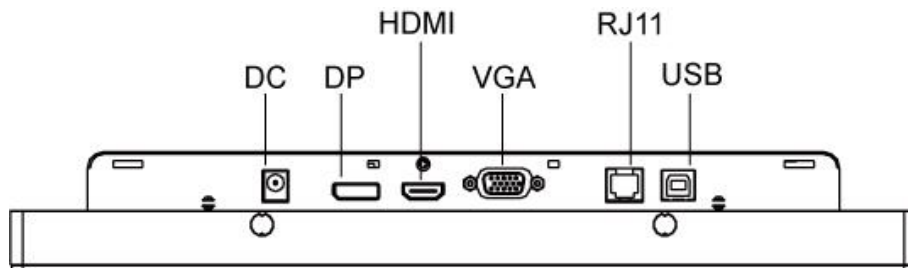

1.5.1 Power Connector

The DC power via external 12V Adapter provide it

1.5.2 Video Signal Connector

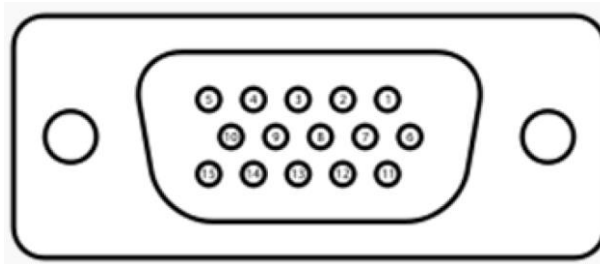

VGA

The video signal input via D-type 15-pin female connector.
Connector Pin Assignment:

| Pin | Signal |
|-----|-----------|
| 1 | RED |
| 2 | GREEN |
| 3 | BLUE |
| 4 | NC |
| 5 | GND |
| 6 | RED_RTN |
| 7 | GREEN_RTN |
| 8 | BLUE_RTN |
| 9 | +5V |
| 10 | GND |
| 11 | NC |
| 12 | SDA |
| 13 | HSYNC |
| 14 | VSYNC |
| 15 | SCL |

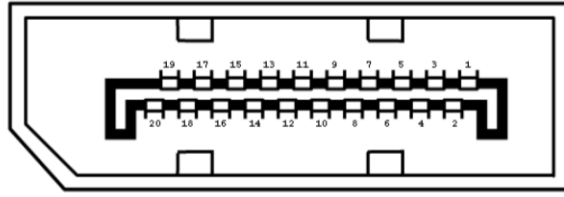

Display Port(1.2a)

| Pin | Signal | Pin | Signal |
|-----|-----------------------|-----|--|
| 1 | ML_Lane 0(p) Data0 + | 11 | Signal ground |
| 2 | Signal ground | 12 | ML_Lane 3(n) Data3 - |
| 3 | ML_Lane 0(n) Data0 - | 13 | Signal ground |
| 4 | ML_Lane 1(p) Data1 + | 14 | Signal ground |
| 5 | Signal ground | 15 | AUX_CH(p) AUX + Signal for Auxiliary Channel |
| 6 | ML_Lane 1(n) Data1 - | 16 | Signal ground |
| 7 | ML_Lane 2(p) Data2 + | 17 | AUX_CH(n) AUX - Signal for Auxiliary Channel |
| 8 | Signal ground | 18 | Hot Plug |
| 9 | ML_Lane 2(n) Data 2 - | 19 | DP_PWR Return |
| 10 | ML_Lane 3(p) Data3 + | 20 | DP_PWR |

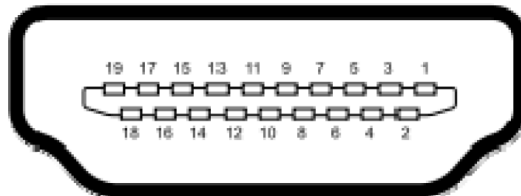

HDMI(1.3) (compatible with HDMI1.4)

| Pin | Signal | Pin | Signal |
|-----|-------------------|-----|---------------------------|
| 1 | TMDS Data2+ | 11 | TMDS Clock Shield |
| 2 | TMDS Data2 Shield | 12 | TMDS Clock- |
| 3 | TMDS Data2- | 13 | CEC |
| 4 | TMDS Data1+ | 14 | Reserved (N.C. on device) |
| 5 | TMDS Data1 Shield | 15 | SCL |
| 6 | TMDS Data1- | 16 | SDA |
| 7 | TMDS Data0+ | 17 | DDC/CEC Ground |
| 8 | TMDS Data0 Shield | 18 | +5V Power |
| 9 | TMDS Data0- | 19 | Hot Plug Detect |
| 10 | TMDS Clock+ | | |

1.5.3 Signal Connector

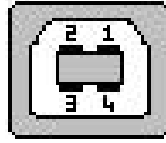

USB Connector



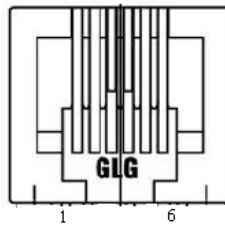

| Pin | Signal | Pin | Signal |
|-----|--------|-----|--------|
| 1 | VCC | 3 | D+ |
| 2 | D- | 4 | GND |

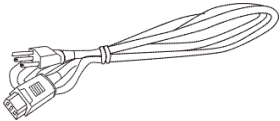
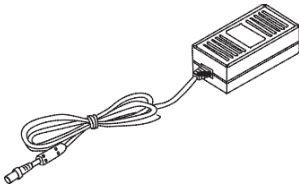

RJ11 Connector (for Remote Key) (option)

| Pin | Signal | Pin | Signal |
|-----|--------|-----|--------|
| 1 | MENU | 4 | SELECT |
| 2 | UP | 5 | POWER |
| 3 | DOWN | 6 | GND |

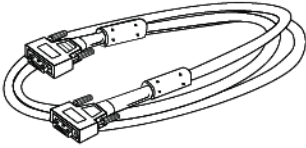
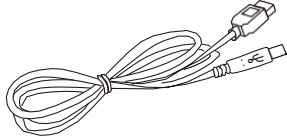
1.6 Package Overview

| | | |
|---|---|---|
|  |  |  |
| LCD Display | Power Cord | DC Power Supply |
|  |  |  |
| HDMI Cable | VGA cable | USB cable (A to B) |
|  |  | |
| M3 screw | Zip bag | |

Warning!

This product is intended to be supplied by a Listed Power Adapter or DC power source, rated 12Vdc, 2.5A minimum, Tma = 40 degree C minimum, and the altitude of operation = 3048m minimum. If it needs further assistance with purchasing the power source, please contact to MicroTouch for further information.

Mise en garde!

Cet appareil est conçu avec une alimentation de courant CA, d'une tension nominale de 12Vdc, 2.5A minimum, Tma = 40 degrés C minimum et l'altitude de l'utilisation = 3048 m minimum. Pour d'autres conseils pour l'installation de la source d'alimentation, communiquer avec MicroTouch pour de plus amples renseignements.

Chapter 2

Product Installation

2.1 About VESA Mount

The DT-150P-M1 series conform to the “VESA Flat Display Mounting Interface Standard” which defines a physical mounting interface for touch monitor, and corresponding with the standards of touch monitor mounting devices. The VESA mount is located on the back of this unit.

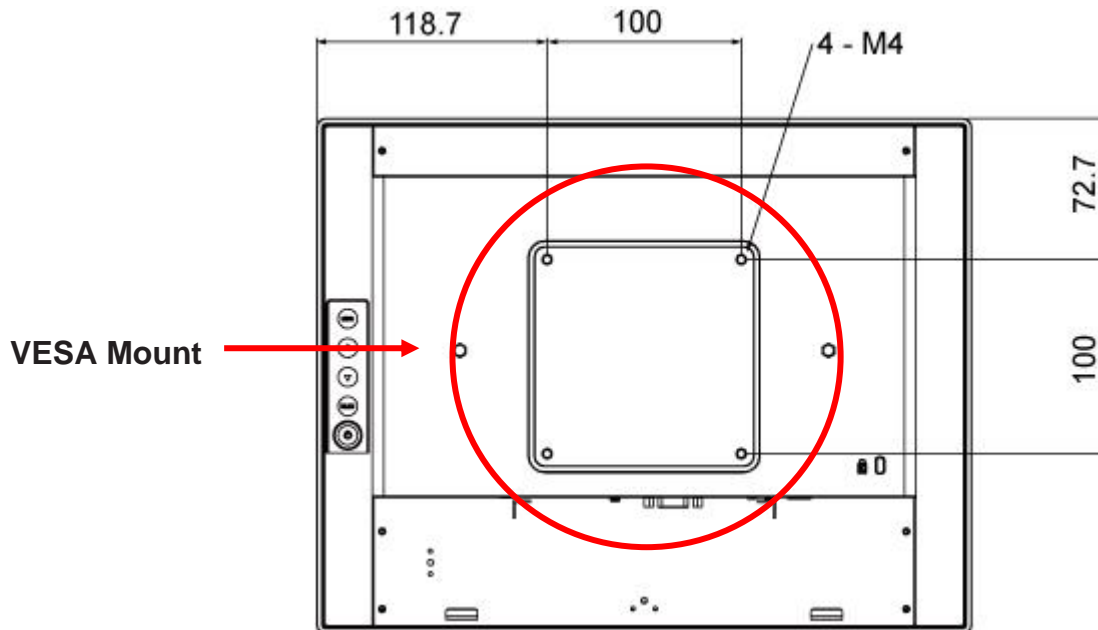

Warning!

*Please select the MicroTouch original screws!
The distance between the back cover surface and the bottom of the screw hole is 8 mm. Please use four M4 screws diameter with 8-10mm proper length to mount your monitor.*

Note: The mounting stand must be able to support at least 7.67 lbs (3.48 Kg).

Mise en garde!

*Sélectionner les vis d'origine de MicroTouch!
La distance entre la surface du couvercle arrière et le bas de l'orifice de la vis est de 8 mm et 18mm. Utiliser les vis M4 de diamètre pour le montage de votre moniteur.*

Remarque : Le support de montage doit pouvoir supporter un poids d'au moins 7.67 lb (3,48kg).

2.2 On-Screen Display

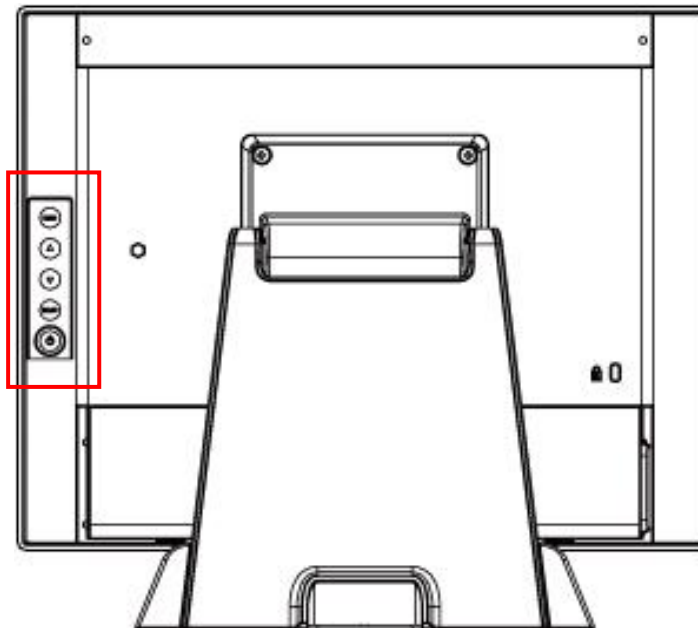

| Key \ OSD | Menu off status | Menu on status |
|---------------|--------------------------------|-------------------------------------|
| MENU | Menu appear | Menu disappear/ return to main item |
| ▲ | Brightness | Main item select up/ Adjust up |
| ▼ | Contrast | Main item select down/ Adjust down |
| SELECT | Enter/Select sub-item function | |
| ⏻ | Power On/Off | |

1. Press the “MENU” button to pop up the “on-screen menu” and press “Up” or “Down” button to select among the four functions in the main menu.
2. Choose the adjustment items by pressing the “SELECT ” button.
3. Adjust the value of the adjustment items by pressing the “Up” or “Down” button.
4. With the OSD menu on screen, press “ Menu” button to return main menu or exit OSD.
5. The OSD menu will automatically close, if you have left it idle for a pre-set time.
6. To Lock / Unlock the OSD / Power menu buttons, press “Menu” and “Minus” at the same time to select.
OSD / Power the Lock / Unlock function.

Please note:

- a. When the OSD Lock function is selected, this indicates that all the buttons except “power” button are now disabled.
- b. When the Power Lock function is selected, this indicates that the power key is disabled; user can not to turn off the monitor by "Power" key.
7. To disable the touch function, press “Menu” and “Enter” Key, at the same time.
8. To enable the touch function, press “Menu” and “Enter” Key, at the same time for five seconds.
9. Press the power key button, there will be an OSD window pop up to ask if it should be going off. If press the power key in five seconds, the monitor power will be off. If don't press the power key in five seconds, the OSD window will be gone and return to the normal status instead.
10. Direct input select function.
 - a. Normal: Press and keep pressing “Select” key for 3 seconds, will change to pop up “source select” OSD.
 - b. Sleep status: Press and keep pressing “Select” key for 1 seconds, will change to pop up “source select” OSD.
11. Factory mode: Press the “MENU” button to pop up the “on-screen menu” and select "Option" icon in "Factory" item, key in password "3","3","3","3" into factory mode.
12. Burn-in mode: In Factory mode to select “Burn In” item into Burin-in mode (unplug signal cable or do not enter the signal source).
13. Work time: In factory mode, displays monitor the work time counting in hours.

2.2.1 OSD Function Description

| Item | Content | Default |
|---------------------------------|---|---------|
| Contrast | The monitor luminance level control. | 50 |
| Brightness | The monitor backlight level control. | 100 |
| H-Positon | Moving screen image horizontal position to left or right. | NA |
| V-Positon | Moving screen image vertical position to up or down. | NA |
| Phase | The screen image horizontal dot clock adjustment. | NA |
| Clock | The screen image pixel phase adjustment. | NA |
| Auto Adjust | Fine-tune the image to full screen automatically. | NA |
| Color Temp | Color temperature selection. (9300K, 6500K, 5500K, 7500K, User) | USER |
| Medical models: Sharpness | Adjust the screen sharpness. | 50 |
| Medical models: Gamma | Gamma / DICOM function mode. (Native, 1.8, 2.2, DICOM) | Native |
| OSD Timeout | OSD auto-disappear time selection. | 15 |
| Medical models: OSD Positon | Moving OSD menu position. | User |
| OSD H-Positon | Moving OSD menu horizontal position to left or right. | 50 |
| OSD V-Positon | Moving OSD menu vertical position to up or down. | 50 |
| Reset | Factory default value restored. | NA |
| OSD Language | OSD menu language selection. (English, French, Deutsch, Italian, Spanish, Japanese, Traditional Chinese and Simplified Chinese) | English |
| Source Select | Select Input function.(Auto, VGA,HDMI,DP) | Auto |
| Medical models: Display port | Display current resolution related information. | NA |
| Medical models: Lum Preset | The monitor backlight function quick mode. (Set1, Set2, Set3, User) | User |
| Factory | Factory mode related adjustment items. | NA |

2.2.2 Timing Table Chart

| Mode | NO | Resolution | H-Freq. (KHz) | Band Width (MHz) | Polarity | |
|------|-----|--------------------|------------------|---------------------|----------|---|
| | | | | | H | V |
| 1 | 102 | 720x400 70Hz | 31.47 | 28.322 | - | + |
| 2 | 103 | VGA 640x480 60Hz | 31.47 | 25.175 | - | - |
| 3 | 182 | MAC 640x480 66Hz | 35 | 30.24 | - | - |
| 4 | 173 | 640x480 72Hz | 37.86 | 31.5 | - | - |
| 5 | 109 | 640X480 75Hz | 37.5 | 31.5 | - | - |
| 6 | 104 | 800x600 56Hz | 35.16 | 36 | + | + |
| 7 | 116 | 800x600 60Hz | 37.88 | 40 | + | + |
| 8 | 110 | 800x600 72Hz | 48.077 | 50 | + | + |
| 9 | 117 | 800x600 75Hz | 46.875 | 49.5 | + | + |
| 10 | 108 | 832x624 (74.55Hz) | 49.722 | 57.28 | - | - |
| 11 | 118 | 1024x768 (60.0 Hz) | 48.363 | 65 | - | - |
| 12 | 157 | 1024x768 (70.0 Hz) | 56.476 | 75 | - | - |
| 13 | 141 | 1024x768 (75.0 Hz) | 60.02 | 78.75 | + | + |

2.2.3 EDID Data

VGA

The monitor assembly shall provide a display communications channel that conforms to VESA DDC2B hardware requirements. This configuration shall contain the 128-byte EDID file as specified by VESA EDID Standard

DP/HDMI

The monitor assembly shall provide a display communications channel that conforms to VESA DDC2B hardware requirements. This configuration shall contain the 256-byte EDID file as specified by VESA EDID Standard

2.3 Dimension

2.3.1 Front View

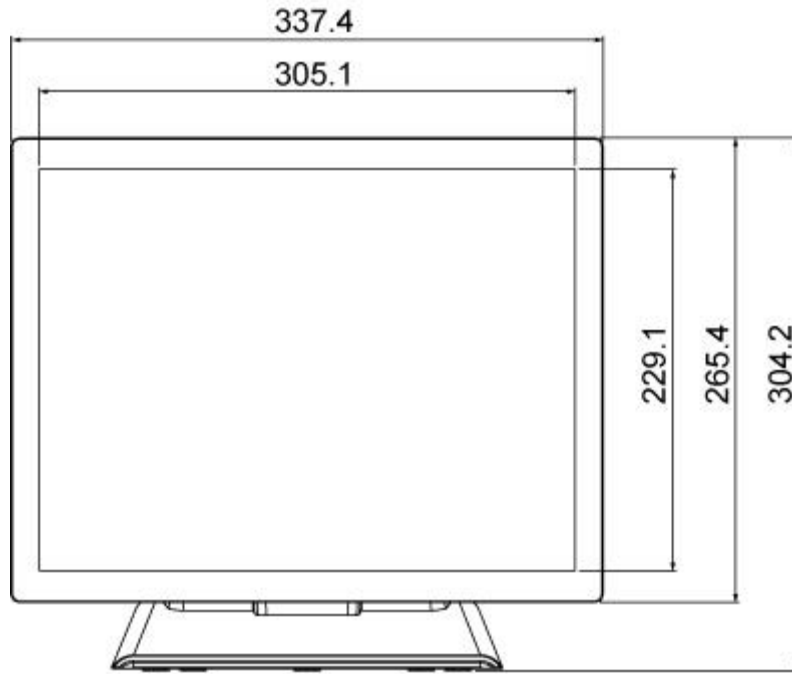

2.3.2 Side View

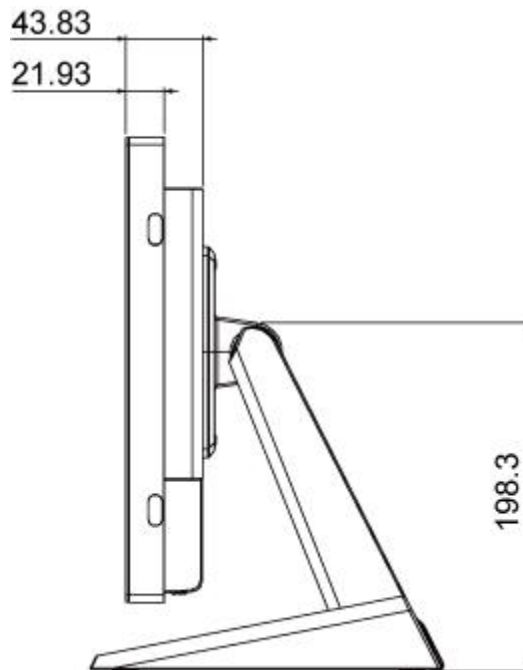

2.3.3 Rear View

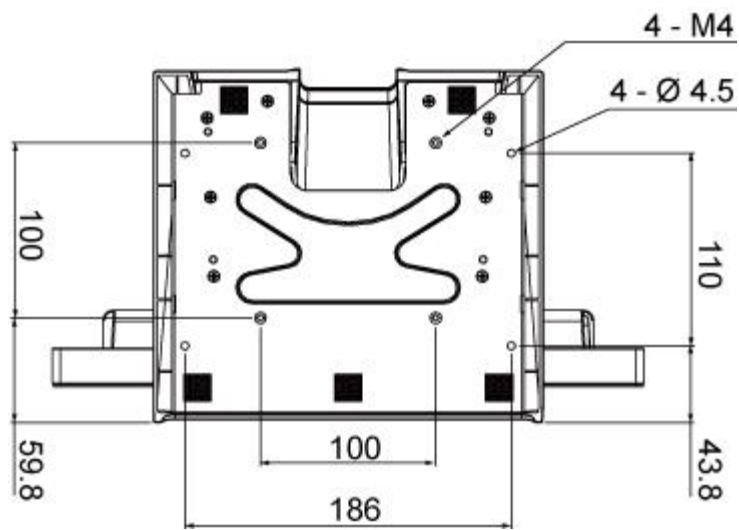
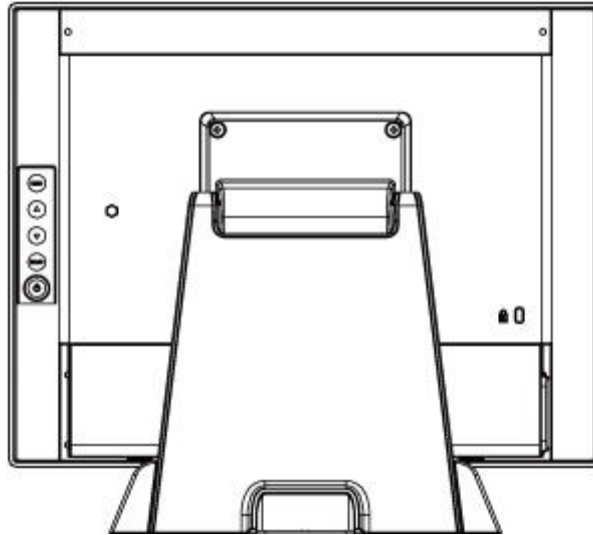

Appendix

Declaration of the Presence Condition of the Restricted Substances Marking

| | | | | | | |
|--|--|---|-------------------|--|--|--|
| 設備名稱：觸控螢幕 Equipment name : Touch LCD Monitor | | 型號（型式）：DT-150P-M1 Type designation (Type) : DT-150P-M1 | | | | |
| 單元 Unit | 限用物質及其化學符號 Restricted substances and its chemical symbols | | | | | |
| | 鉛 Lead (Pb) | 汞 Mercury (Hg) | 鎘 Cadmium (Cd) | 六價鉻 Hexavalent chromium (Cr ⁺⁶) | 多溴聯苯 Polybrominated biphenyls (PBB) | 多溴二苯醚 Polybrominated diphenyl ethers (PBDE) |
| 塑膠零件 Plastic Parts | ○ | ○ | ○ | ○ | ○ | ○ |
| 金屬零件 Metal Parts | - | ○ | ○ | ○ | ○ | ○ |
| 線纜和電纜組件 Cable component | - | ○ | ○ | ○ | ○ | ○ |
| LCD 面板 LCD Panel | - | ○ | ○ | ○ | ○ | ○ |
| 觸控式螢幕面板 Touch Panel | - | ○ | ○ | ○ | ○ | ○ |
| PCBA | - | ○ | ○ | ○ | ○ | ○ |
| 軟體(CD 等) Software | ○ | ○ | ○ | ○ | ○ | ○ |
| <p>Note 1 : “Exceeding 0.1 wt %” and “exceeding 0.01 wt %” indicate that the percentage content of the restricted substance exceeds the reference percentage value of presence condition. °</p> <p>Note 2 : “○” indicates that the percentage content of the restricted substance does not exceed the percentage of reference value of presence.</p> <p>Note 3 : The “-” indicates that the restricted substance corresponds to the exemption.</p> | | | | | | |